

ULTRA DIMENSION™ 700

Automated Optical Inspection (AOI)

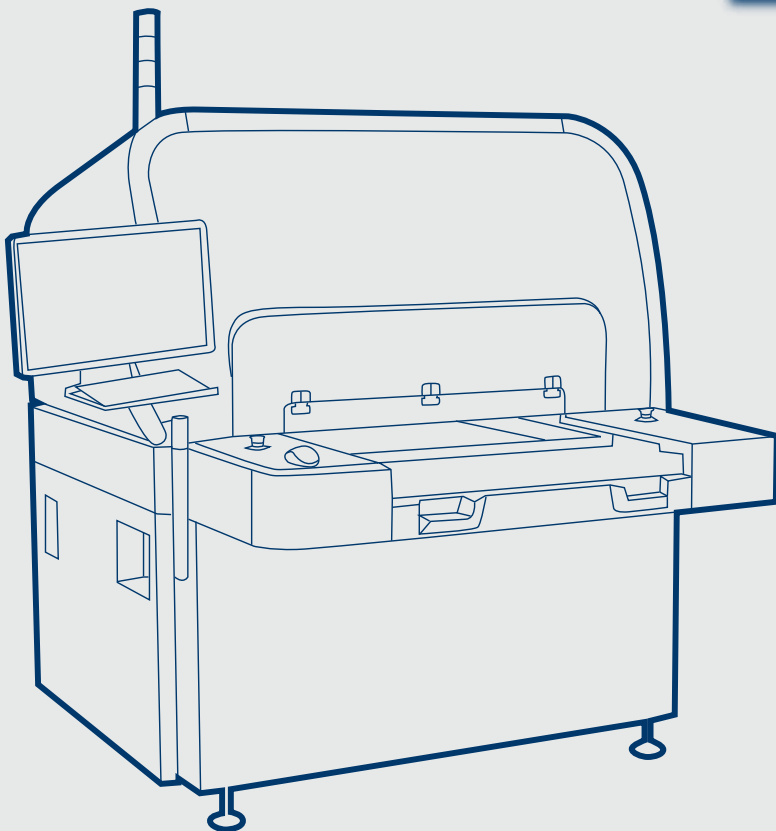

PCB Production Solutions

ULTRA DIMENSION™ 700

The Start of a New Era

Ultra Dimension™ 4-in-1 AOI Solution

The Ultra Dimension series is revolutionizing the AOI room workflow for advanced PCB production, including SLP, mSAP, advanced HDI, advanced Flex and IC substrates. Built to meet the market's constantly evolving requirements for quality and reliability, the Ultra Dimension is the first AOI solution to integrate best-in-class pattern inspection, laser via (LV) inspection, Remote Multi-Image Verification (RMIV) and 2D metrology in a single groundbreaking system.



Benefits

Unique Inspection Capabilities

- First solution to perform both pattern and laser via inspection in a single scan enabled by Orbotech's Triple Vision Technology™
- Significant reduction in false alarms without having to use inspection masks enabled by Magic Technology™
- Dedicated inspection channels for all stages of laser via production

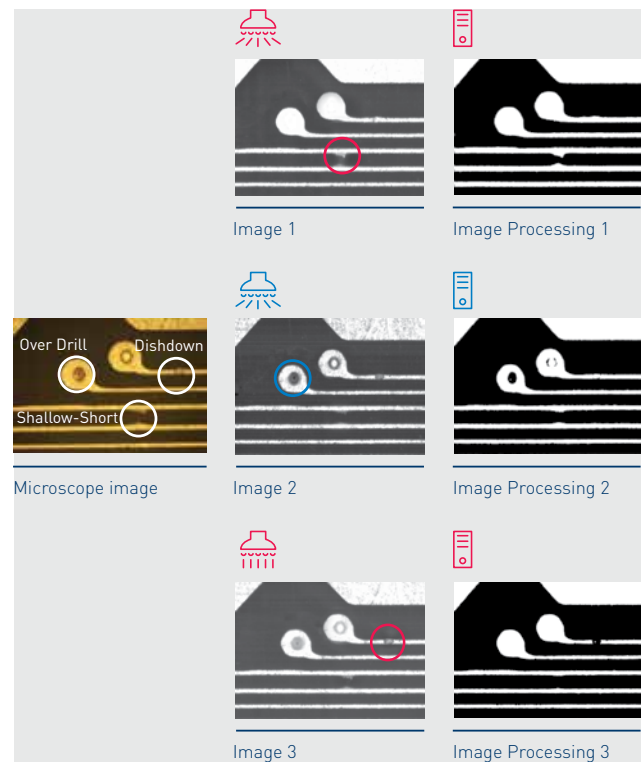

Remote Multi Image Verification (RMIV) - New Approach to Verification

- Automated simultaneous 'grabbing' of defect multi-images
- Significantly shorter verification cycle time than existing solutions
- Major reduction in quantity of standard verification stations and operators

Integrated, Automated 2D Metrology

- Unique capability to measure at both top and bottom conductor widths ensuring higher reliability and tight impedance control



- Significantly faster 2D measurement cycle time
- Traceability and data analysis enabled by digitalized process

Lower Total Cost of Ownership (TCO)

- More than 30% reduction in overall TCO
- Significantly lower labor costs
- Far less floor space required

4 Best-in-Class AOI Solutions in a Single System

Ultra Dimension combines four best-in-class solutions in a single system, delivering new capabilities that further improve quality, yield and cost-efficiency. Combined together, these solutions signify a revolution in the AOI room workflow, representing a new era in AOI efficiency.

Unique Inspection Capabilities

Ultra Dimension is the first AOI solution to perform both pattern and laser via inspection in a single scan. Powered by Orbotech's proprietary Triple Vision Technology™ and Magic Technology™, it delivers superior pattern inspection results across the board, from improving detection to reducing false alarms to decreasing set up time. Ultra Dimension provides manufacturers of advanced PCB processes with the flexibility to inspect a variety of applications and materials without any compromise.

Triple Vision technology enables simultaneous inspection and analysis of three different types of images using varied light settings and thresholds as required. This leads to the highly accurate detection and classification of a wide variety of defect types including fine shorts, dish downs, laser via shifts, laser via under/overdrilling and more.

Magic technology dramatically reduces false alarms. Driven by state of the art artificial intelligence (AI), Orbotech's Magic Technology removes the need to use inspection masks which can cause defects to be missed.

Remote Multi Image Verification (RMIV) - New Approach to Verification

Ultra Dimension enables the remote verification of multiple images which are automatically and simultaneously grabbed during the inspection process. By integrating images from three channels into a single multi-color image, the solution enables operators to accurately differentiate between real and false defects in far less time than the current industry standard. This leads to a significantly faster verification cycle time as well as a reduction in the number of required verification stations and the labor and floor space needed.

Integrated, Automated 2D Metrology

Orbotech's 2D metrology enables automatic measurement of both top and bottom conductor widths. This answers the market's increasing demand for the higher accuracy and impedance control necessary for SLP/mSAP, advanced HDI, HLC & Automotive applications. This process, which is fully automated, ensures fast, accurate and repeatable measurement. Complete digitalization of the process means that it also fully supports traceability and data analysis. Orbotech 2D metrology is renowned for its exceptionally fast and accurate solution, achieving results in seconds.

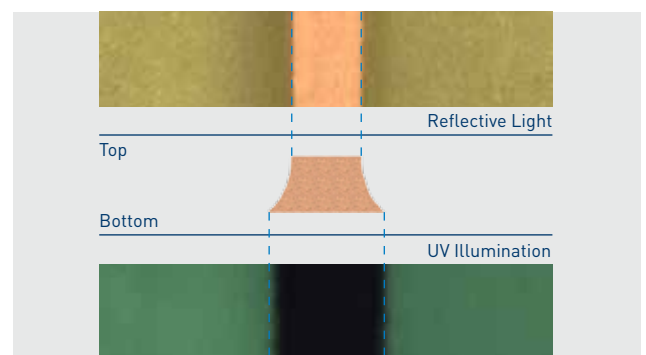

Lower Total Cost of Ownership (TCO)

By combining 4 best-in-class solutions into a single system, Ultra Dimension is the most efficient solution available today for the AOI room. This new system dramatically reduces the number of machines required, freeing up valuable floor space in the AOI room. By cutting the number of verification stations needed, the Ultra Dimension also enables manufacturers to significantly lower their labor costs as well as their overall TCO.